



Nuclear Services/Repair, Replacement and Automation Services

# Nuclear Safety Related Low-Voltage Power Circuit Breakers and Cell Parts – Types DS and DSL

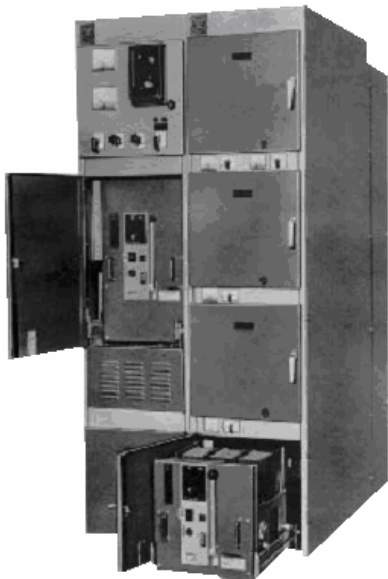

Figure 1 – Switchgear cell

This publication covers the following breakers.

Breaker Type	Frame Size Amperes
DS-206	600 & 800
DSL-206	600 & 800
DS-416	1600
DSL-416	1600
DS-420	2000
DS-532	3200
DS-632	3200

Index	
Subject	Page Number
Parts Identification	3
Breakers and Refurbishments	3
Maintenance Interval and Service Life	3
Recommended Spare Parts	3
Common Parts	5
Pole Units	6-8
Arc Chutes and Barriers	9
Operating Mechanism and Related Parts	10-11
Control Components	12-13
Levering Mechanism	14
Westector Tripping System	15
Auxiliary Switches	16
DSL-206 and DSL-416	17
Miscellaneous Switchgear Parts	18-19
Identify Breaker Type	20
Order Instructions and Form	20

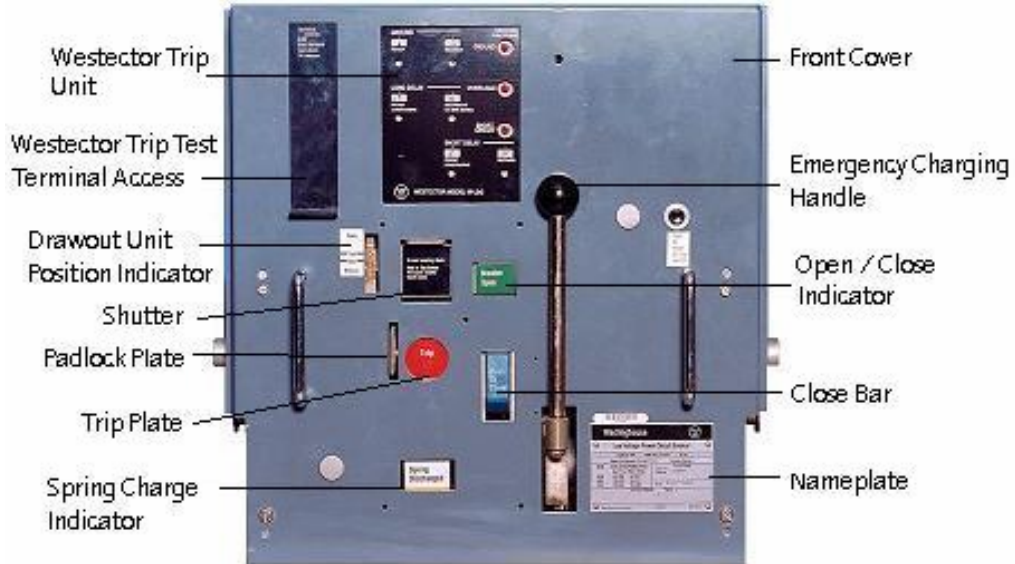

Figure 2 – View showing controls on the panel

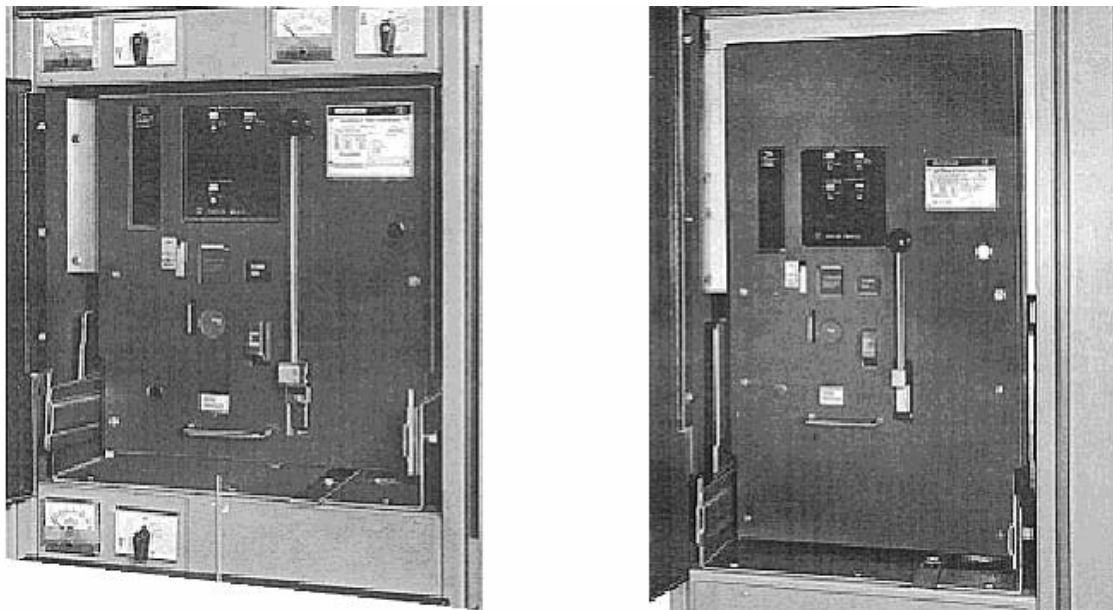

Figure 3 – Type DS-206 and Type DS-632 breakers in connected position

**Parts Identification**

Renewal Parts Data  
RPD RCS/PS-11-060/08



The illustrations in this Renewal Parts Data (RPD) show parts and sub-assemblies which are identified by name and part number. Additional information and illustrations are shown in the Maintenance Program Manual (MPM-DS Breaker) which shows many sub-assemblies and detail parts in order to illustrate their function and location in the assembly. Some of the detail parts are shown in the manual only as part of a sub-assembly to facilitate their replacement or installation in the field. The availability of parts and sub-assemblies is indicated by part number in the following pages.

If the item in question cannot be identified by part number, refer to the Figure number, name and item number as shown in this RPD along with the breaker type and its shop order number as shown on the nameplate on the front cover of the circuit breaker.

Complete Replacement Circuit Breakers A		
Model Number	Description	Part Number
DS-206	Manually Operated Circuit Breaker	151D062G01
DS-206	Power Operated Circuit Breaker	151D062G02
DS-416	Manually Operated Circuit Breaker	151D062G03
DS-416	Power Operated Circuit Breaker	151D062G04
DS-420	Manually Operated Circuit Breaker	151D062G05
DS-420	Power Operated Circuit Breaker	151D062G06
DS-632 B	Manually Operated Circuit Breaker	151D062G07
DS-632 B	Power Operated Circuit Breaker	151D062G08
DSL-206	Manually Operated Circuit Breaker	140D776G01
DSL-206	Power Operated Circuit Breaker	140D776G02
DSL-416	Manually Operated Circuit Breaker	140D776G05
DSL-416	Power Operated Circuit Breaker	140D776G06

- A. The shop order number of the breaker being replaced must be provided at time of RFQ or order entry.
- B. DS-632 breakers supersede DS-532 breakers.

Circuit Breaker Refurbishments A		
Model Number	Description	Part Number
DS-206	Manually Operated Circuit Breaker	151D062G01R
DS-206	Power Operated Circuit Breaker	151D062G02R
DS-416	Manually Operated Circuit Breaker	151D062G03R
DS-416	Power Operated Circuit Breaker	151D062G04R
DS-420	Manually Operated Circuit Breaker	151D062G05R
DS-420	Power Operated Circuit Breaker	151D062G06R
DS-532	Manually Operated Circuit Breaker	449D555G05R
DS-532	Power Operated Circuit Breaker	449D555G06R
DS-632	Manually Operated Circuit Breaker	151D062G07R
DS-632	Power Operated Circuit Breaker	151D062G08R
DSL-206	Manually Operated Circuit Breaker	140D776G01R
DSL-206	Power Operated Circuit Breaker	140D776G02R
DSL-416	Manually Operated Circuit Breaker	140D776G05R
DSL-416	Power Operated Circuit Breaker	140D776G06R

- A. The circuit breaker requiring refurbishment must be shipped to the RRAS New Stanton, PA Service Center.

**Circuit Breaker Maintenance Interval and Service Life Recommendations, in Number of Cycles A, B.**

Breaker Type	Maintenance Interval	Service Life Limitation
DS-206, DSL-206	1750	12500
DS-416, DSL-416, DS-420	500	4000
DS-532, 632	250	1500

Breaker Devices & Cell Parts	Service Life Limitation
Spring Charging Motor	8000
Spring Release Device (SRD)	8000
Shunt Trip Attachment (STA)	8000
Under Voltage Trip Attachment (UVTA)	2500
Direct Trip Actuator (DTA)	400
Over Current Trip Switch (OTS)	400
Cell Switch	400
Breaker Primary Finger Clusters	400
Breaker and Cell Secondary Contacts	400

- A. Breaker cycle – One no load open / close operation
- B. Device cycle – One operation of the device. That is, for each Westector / Amptector initiated trip, the DTA and OTS operates once; for each electrical breaker CLOSURE the SRD operates once; for each electrical breaker OPEN, the STA operates once; for each levering in and out of the cell to the CONNECTED position, the Levering-In assembly, the cell switch, breaker primary finger clusters and breaker secondary contact assemblies operate once.

Notes: The UVTA is reset with every cycle of the breaker, regardless of the method of trip. The original seismic testing of the OTS switch showed contact bounce in excess of 200 milliseconds. The 8000 cycle life of the Charging Motor, SRD and STA are for the DS-206 and DSL-206 breakers only. In the other applications the life of these devices is limited, by test, to the breaker limits.

**Recommended Spare Parts**

Spare parts recommended for stocking are indicated in the following data by the symbol ®. An adequate stock of spare parts will help minimize emergency situations and can substantially reduce production down time.

The amount of investment to be made in spare parts stock can be dependent on a number of individual factors. The item recommended and the quantities specified below are intended as a guide.

- For 1 to 5 Breakers – 1 set of items marked ®, in sufficient quantity for one breaker
- For 6 to 10 Breakers – 2 sets of items marked ®, in sufficient quantity for two breakers
- For 10 or more Breakers – One complete spare breaker for every 10 breakers and 2 sets of items marked ®

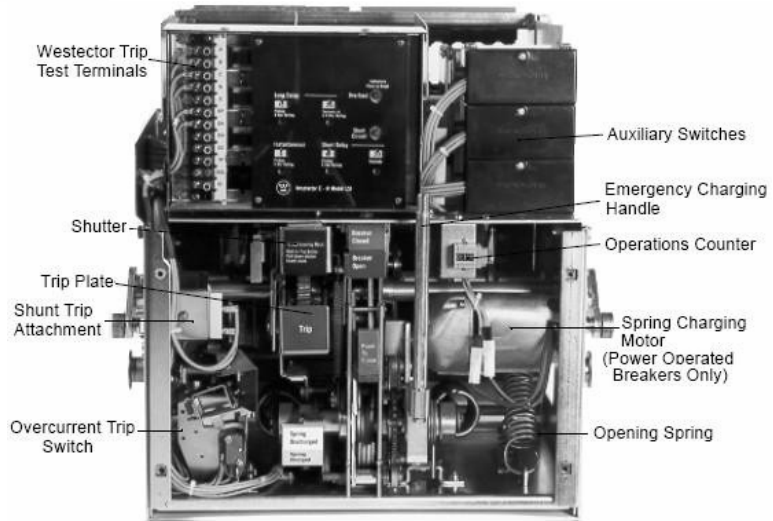

Figure 4 – DS 416 breaker with front panel removed

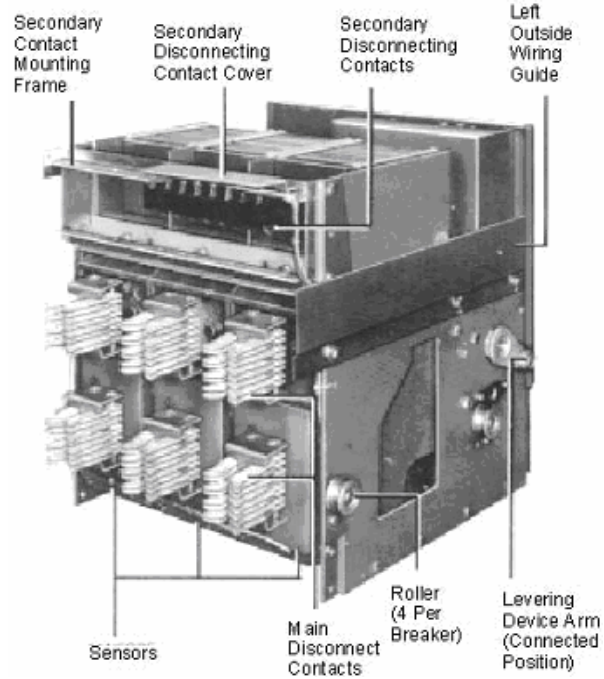

Figure 5 - Rear view showing levering device arm in connect position



**Items Common to All Breaker Types**

**Hardware**

Standard hardware such as bolts, nuts, washers, etc. are not listed in this data. Damaged or worn hardware should be replaced with hardware of SAE grade 5 or better, and purchased locally where available.

DS Breaker Fastener Kit 3586A86G01

Kit includes an assortment of retaining rings, tru-arc rings, 'E' rings and 'X' washers in a plastic bag. One kit is recommended for 1 breaker, two for 2 to 5 breakers, three for 6 to 20 breakers, and four for over 20 breakers.

Lubricants	Part Number
Graphite Grease, 1 qt.	53701AN00T
Lubriplate 130A, 14 oz.	53701HE10Q
MolyKote BR2 Plus, 14.1 oz.	53701QB12J

Material Safety Data Sheets are available for the lubricants listed, but will only be provided when specifically requested on the order.

Breaker Operational & Test Accessories	Part Number
Westector / Amptector Test Kit	8779C02G02
Arcing Contact Adjustment Tool	795A076TXC
Arcing Contact Gap Tool	012693-1
Closing Spring Tool	567F467TXA
Levering Crank	436B696G01
Lifting Bar & Hook Assembly	694C614G02
Primary Contact Disconnect Tool	591C901G01
UVTA Trip Margin Gage	693C354G01

Breaker Front Cover and Accessories	Part Number
<b>Faceplates A</b>	
DS-206, DS-416, DS-420	567F498H01
DS-532, DS-632	567F499H01
DSL-206, DSL-416	567F498H02
<b>Breaker Labels</b>	
Label Kit	8187A84G01
includes the following labels:	
Auxiliary Switch	
Danger Sign	
Levering Position Indicator	
Levering Shutter	
Spring Charged/Discharged	
Trip Button	
<b>Other Parts</b>	
Faceplate Handle	72060BA00B
Westector Terminal Cover	591C470H01

- A. Faceplates do not include labels, handles, or terminal cover. Order these separately.

**Manual**

MPM-DS BREAKER Maintenance Program Manual for Safety Related Type DS Low Voltage Metal Enclosed Switchgear

Miscellaneous Breaker Parts	Figure	Part Number
Breaker Rollers A	5	349A473H01
Compartment Trip Lever (All DS Breakers except DS-532/632)	-	8295A03G01
Compartment Trip Lever DS-532/632	-	8295A15G01
DS-206, 416 Breaker Interference Bracket	-	435B461H01
Operations Counter - Left Hand	-	592C890G01
Operations Counter - Right Hand	4	698B825G01
Pole Shaft Kit b, c	-	680C790G01 KIT
Secondary Contact Frame	-	5D63640G01
Secondary Disconnect Contact Block - 8 contacts d	5	591C498G06
Secondary Disconnect Contact Cover d	5	503B569H01
Seismic Positioner	24	795A493H01

- A. Fastener kit required when ordering rollers.
- B. Not applicable for DS-532/632 breakers.
- C. For DS-532/632 pole shafts, contact RRAS with original shop order information.
- D. Includes mounting hardware.

Wire Guides A	Figure	Part Number
Inside Left	-	3702A37G01
Outside Left	5	437B224H01
Rear of Westector	-	588C990H01
Right of Westector	-	436B111H01

- A. Wiring guides, when used, are located on the left side of the breaker with inside and outside guides. One guide is also located at the rear of the Westector and one between the right side of the Westector and auxiliary switches.

DS Breaker Spring Kit	1	4A48813G10
Spring, Anti-Bounce Reset, DS	1	788A549H01
Spring, Hold Pawl, DS	1	349A481H02
Spring, Latch (Close Prop), DS	1	794A207H01
Spring, Motor Cut-Off Switch, DS	1	436B621H03
Spring, Oscillator Reset, DS	1	503B601H11
Spring, Overcurrent Trip Switch Reset, DS	1	436B621H07
Spring, Pushbutton, DS	1	503B603H01
Spring, Reset / Opening, DS	1	698B907H01
Spring, Shutter, DS	1	503B410H18
Spring, Spring Charged Indicator, DS	1	436B621H06
Spring, Trip Latch Reset, DS	1	795A077H01
Spring, Trip Shaft Return, DS	1	436B621H05



Type DS-206 and DSL-206 Pole Unit  
 DS-206 Pole Unit is illustrated. DSL-206 Pole Unit is similar.

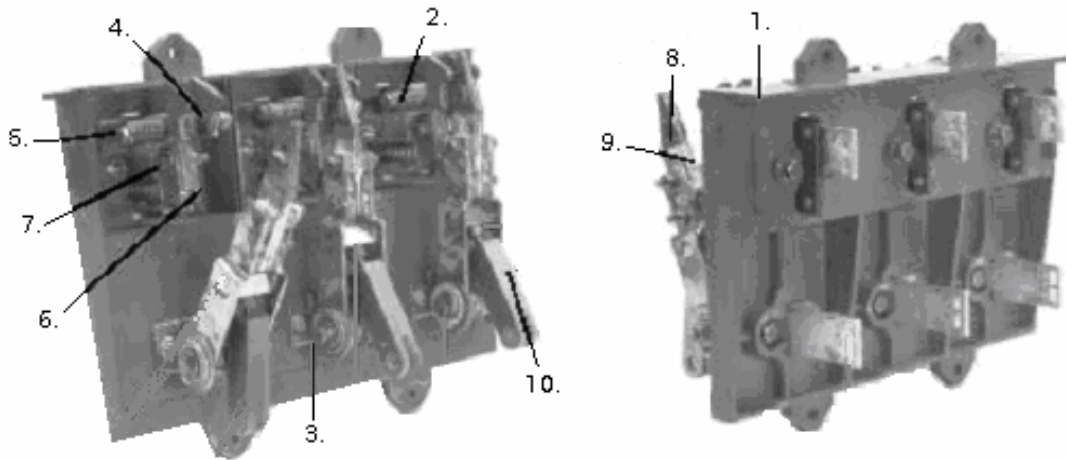

Figure 6 – DS-206 pole unit assembly (front view left and rear view)

Description	Figure Number	Item Number	DS-206		DSL-206 A	
			Number Required Per Breaker	Part Number	Number Required Per Breaker	Part Number
Three Pole Unit Assembly Complete	6		1	140D152G05	1	140D152G07
Following are included in Three Pole Unit Assembly:						
Molded Base	6	1	1	140D150H01	1	140D150H01
Upper Stud Assembly		2	3	591C653G01	3	591C653G03
Lower Stud Assembly		3	3	591C652G01	3	591C652G03
Following are included in Upper Stud Assembly:						
Stationary Arcing Contact - R.H.	6	4	3Ⓢ	682C829G01	3Ⓢ	682C829G01
Stationary Arcing Contact - L.H.	6	4	3Ⓢ	682C829G02	3Ⓢ	682C829G02
Stationary Arcing Contact Spring	6	5	6Ⓢ	503B027H01	6Ⓢ	503B027H01
Stationary Main Contact Finger	6	6	6Ⓢ	809A263G01	6Ⓢ	809A263G01
Stationary Main Contact Spring	6	7	3Ⓢ	503B027H08	3Ⓢ	503B027H08
Following are included in Lower Stud Assembly:						
Moving Arcing Contact	6	8	3Ⓢ	682C828G01	3Ⓢ	682C828G01
Moving Main Contact	6	9	6Ⓢ	591C651G01	6Ⓢ	591C651G01
Insulating Link Assembly	6	10	3	788A588G01	3	788A588G01
Pin for Insulation Links <sup>b</sup>						
Center Pole	6		1	666A347H17	1	666A347H17
Left and Right Pole	6		2	3755A23H01	2	3755A23H01
Main Disconnecting Contact Assembly <sup>c</sup>	5		6	591C655G02	6	591C655G02

- A. See page 17, Figure 17-1, for illustration of the DSL-206
- B. X-washers for pin installation listed on page 5 under DS Circuit Breaker Fastener Kit
- C. Not included in pole unit assembly
- Ⓢ Recommended Spare - see page 3



Type DS-416, DSL-416, and DS-420 Pole Unit  
 DS-416 Pole Unit is illustrated. DSL-416 and DS-420 Pole Units are similar.

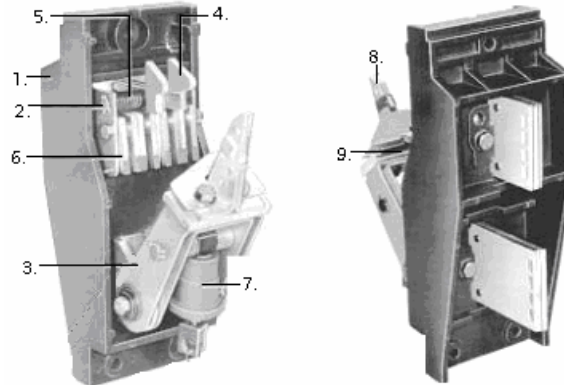

Figure 7 – DS-416 pole unit assembly (front view left and rear view)

Description	Figure Number	Item Number	DS-416		DSL-416 A		DS-420	
			Number Required Per Breaker	Part Number	Number Required Per Breaker	Part Number	Number Required Per Breaker	Part Number
Single Pole Unit Assembly Complete	7		3	151D064G01	3	151D065G01	3	151D065G02
Following are included in Single Pole Unit Assembly:								
Molded Base	7	1	3	553F204H01	3	553F204H01	3	553F204H01
Upper Stud Assembly- Stationary	7	2	3	591C750G02	3®	139D635G01	3®	139D635G01
Lower Stud Assembly- Moving	7	3	3	126D298G06	3	139D633G04	3®	139D633G04
Following are included in Upper Stud Assembly:								
Stationary Arcing Contact - R.H.	7	4	3®	682C829G01	3®	682C829G01	3®	682C829G01
Stationary Arcing Contact - L.H.	7	4	3®	682C829G02	3®	682C829G02	3®	682C829G02
Stationary Arcing Contact Spring	7	5	6®	503B027H01	6®	503B027H01	6®	503B027H01
Stationary Main Contact Finger	7	6	24®	809A263G01	36 B	809A263G01	36 B	809A263G01
Stationary Main Contact Spring - Outer	-	-	12®	503B027H05	12 B	503B027H05	12 B	503B027H05
Stationary Main Contact Spring - Inner	-	-	-	-	12 B	503B027H10	12 B	503B027H10
Following are included in Lower Stud Assembly:								
Moving Arcing Contact	7	8	3®	682C827G01	3®	682C827G01	3®	682C827G01
Moving Main Contact	7	9	3®	665A321G01	3®	795A769G01	3 c	795A769G01
Insulating Link Assembly	7	7	3	436B450G02	3	436B450G02	3	436B450G02
Pin for Insulation Links D								
Center Pole	6	-	1	666A347H17	1	666A347H17	1	666A347H17
Left and Right Pole	6	-	2	3755A23H01	2	3755A23H01	2	3755A23H01
Main Disconnecting Contact Assembly E	5	-	6	682C347G01	6	682C347G01	6	590C804G01

- A. See page 17, Figure 17-2, for illustration of the DSL-416
- B. Assembly of the stationary main contact fingers and inner and outer springs is difficult. The Upper Stud Assembly is recommended for the DSL-416 and DS-420.
- C. Changing the moving main contact is complicated because of a drilling and pinning operation. The Lower Stud Assembly is recommended for the DS-420.
- D. X-washers for pin installation listed on page 5 under DS Circuit Breaker Fastener Kit
- E. Not included in pole unit assembly
- ® Recommended Spare - see page 3



**TYPE DS-532 AND DS-632 POLE UNIT**

DS-632 Pole Unit is illustrated and is the replacement for DS-532 Pole Unit.

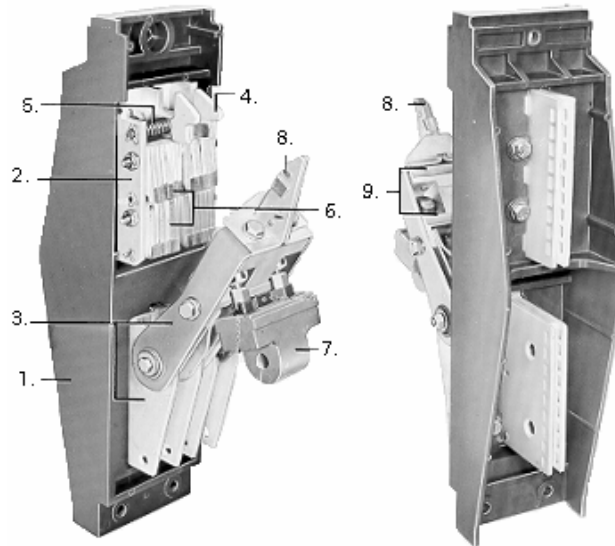

Figure 8 – DS-632 pole unit assemblies (front view left, rear view right)

Description	Figure Number	Item Number	DS-532 & DS-632	
			Number Required Per Breaker	Part Number
Single Pole Unit Assembly Complete	8		3	567F962G01
Following are included in Single Pole Unit Assembly:				
Molded Base	8	1	3	553F205H01
Upper Stud Assembly	8	2	3 <sup>Ⓢ</sup>	126D299G02
Lower Stud Assembly	8	3	3 <sup>Ⓢ</sup>	140D091G05
Following are included in Upper Stud Assembly:				
Stationary Arcing Contact - R.H.	8	4	3 <sup>Ⓢ</sup>	682C829G01
Stationary Arcing Contact - L.H.	8	4	3 <sup>Ⓢ</sup>	682C829G02
Stationary Arcing Contact Spring	8	5	6 <sup>Ⓢ</sup>	503B027H01
Stationary Main Contact Finger	8	6	72 A	809A263G01
Stationary Main Contact Spring - Outer	-	-	24 A	503B027H05
Stationary Main Contact Spring - Inner	-	-	24 A	503B027H10
Following are included in Lower Stud Assembly:				
Moving Arcing Contact	8	8	3 <sup>Ⓢ</sup>	682C826G01
Moving Main Contact	8	9	3 B	794A105G01
Insulating Link Assembly	8	7	3	680C792G03
Pin for Insulation Links c	8		3	666A347H07
Main Disconnecting Contact Assembly d	5		6	682C347G02

- A. Assembly of the stationary main contact fingers and inner and outer springs is difficult. The Upper Stud Assembly is recommended.
- B. Assembly of the moving main contact is difficult. The Lower Stud Assembly is recommended.
- C. X-washers for pin installation listed on page 3 under DS Circuit Breaker Fastener Kit.
- D. Not included in pole unit assembly
- Ⓢ Recommended Spare - see page 3



Arc Chutes and Barriers

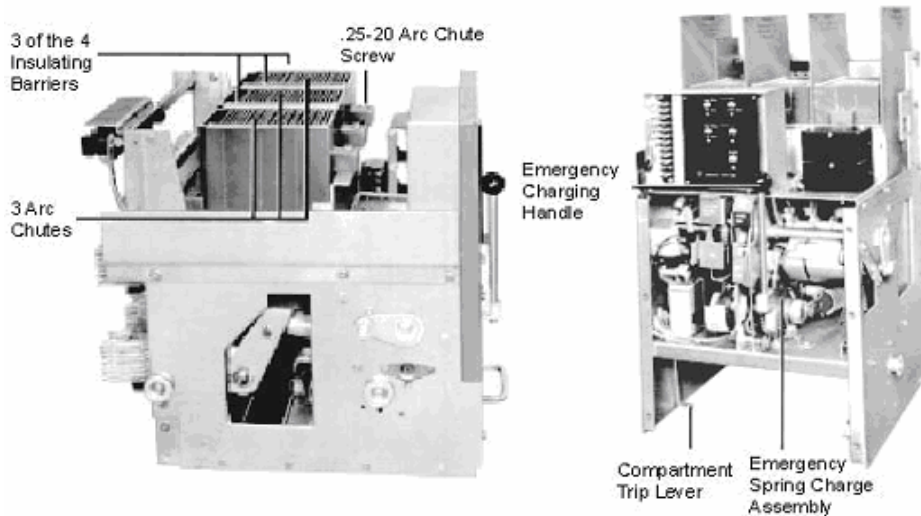

Figure 9 –Left - Breaker with barrier removed to show mounting arc chutes and Right - DS-632 Breaker with front panel removed

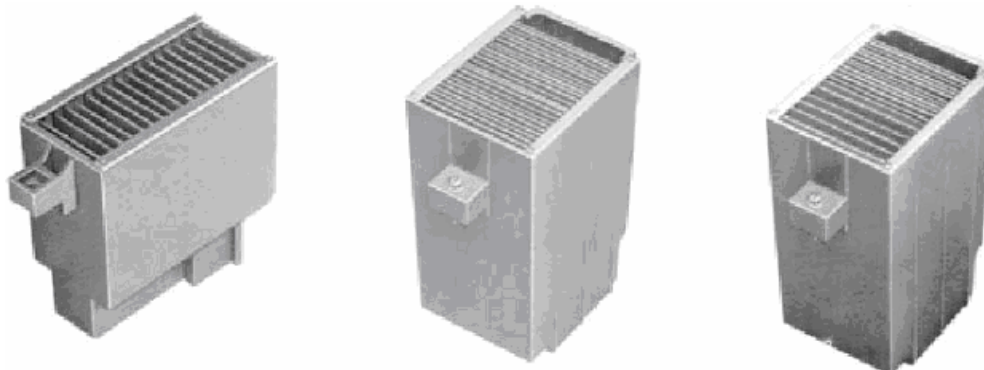

Figure 10 – Left - DS-206 arc chute, Middle - DS-416 / 420 arc chute, and Right - DS-532 / 632 arc chute

Breaker Type	Figure Number	Assembled Arc Chute & Mounting Screw		Outer Removable Insulating Barriers		Inner Removable Insulating Barriers	
		Number Required Per Breaker	Part Number	Number Required Per Breaker	Part Number	Number Required Per Breaker	Part Number
DS-206 DSL-206	9	3	449D508G01	2	349A578H01 A	2	788A586H01
DS-416 DSL-416 DS-420	9	3	151D018G01	2	349A578H01	2	349A578H01
DS-532 B DS-632 C	9	3	151D018G02	2	436B108H02	2	436B108H01

- A. Except for early vintage pole bases with end notches, use 788A586H01
- B. DS-532 arc chutes and insulating barriers must be replaced as sets when replaced the first time.
- C. DS-632 non-removable side insulation 2-PCS 436B109H01

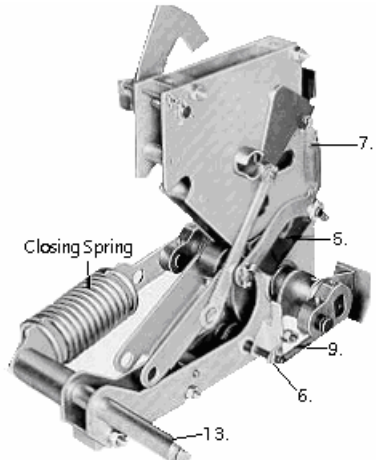

Figure 11 – Left side view of power operated mechanism with left hand closing spring removed

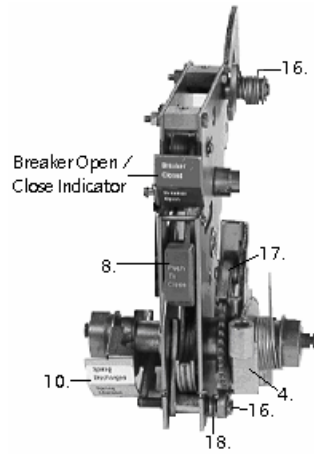

Figure 13 – Front view of power operated mechanism

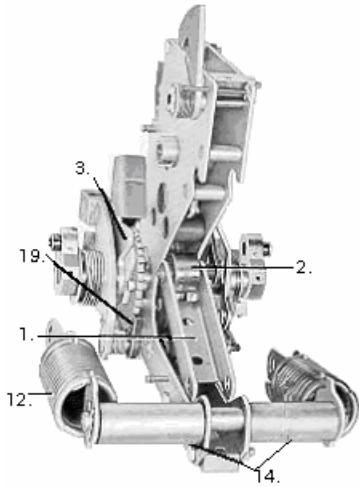

Figure 12 – Rear view of power operated mechanism

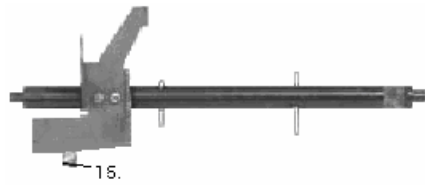

Figure 14 – Trip shaft

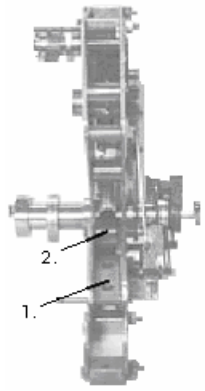

Figure 15 – Rear view manual mechanism with closing spring assembly removed



**Operating Mechanism and Related Parts**

Description	Number Required per Breaker	Power Operated			Manual Operated		
		Figure Number	Item Number	Part Number	Figure Number	Item Number	Part Number
Mechanism Assembly (includes one set of appropriate, Closing Springs, (1) Anchor Pin, (1) RH and (1) LH Spacer)		13			15		
DS-206	1			2A10022G02			2A10022G01
DS-416	1			2A10022G06			2A10022G05
DS-420	1			2A10022G04			2A10022G03
DS-532	1			2A10022G10			2A10022G09
DS-632	1			2A10022G08			2A10022G07
<b>Following are included in Mechanism Assembly:</b>							
Mechanism Assembly A	1			567F759G02			567F759G01
Mechanism Assembly (DS 532/632) A	1			567F759G04			567F759G07
Closing Spring Assembly includes one (1) set of appropriate springs, one (1) Anchor Pin, one (1) RH and Spacer and one (1) LH Spacer as follows:	1	12	12		12	12	
DS-206 Spring A	2			349A521G01			349A521G01
DS-416 Spring A	2			791A671G02			791A671G02
DS-420 Spring A	2			791A671G01			791A671G01
DS-532 Spring A	2			791A671G01			791A671G01
DS-632 Spring A	2			791A671G03			791A671G03
Anchor Pin A	1	11	13	349A515H01	11	13	349A515H01
Anti Bounce Reset Spring	1	13	16	788A549H01	15		788A549H0
Charging Plate A	2			794A966H01			794A966H01
Emergency Charge Device A	1	13	4	436B925G01			D
Emergency Charge Pawl Assembly	1	12		795A069H01			D
Emergency Pawl Assembly	1	12	19	794A117G02			D
Hold Pawl Assembly A	1	13	16	794A117G01			D
Hold Pawl Spring	1	13	18	349A481H02			D
Label - Breaker Open / Closed B	1	13			13		
Label - Spring Charged / Discharged B	1	13	10		13	10	
Left Hand Spacer A	1	12	14	786A258H03	12	14	786A258H03
Lever (For motor cut-off switch)	1	11	6	791A516H01	11	6	791A516H01
Main Drive Link Assembly (with Banana Link)	1			437B146G01			437B146G01
Main Drive Link Assembly (with Banana Link) DS 532/632	1			437B146G02			437B146G01
Main Drive Link Assembly c	1	12		437B146G03	15	1	437B146G03
Main Drive Link Assembly DS 532/632 c	1	12		437B146G04	15	1	437B146G03
Motor Cut-off Switch Spring	1			@436B621H03			@436B621H03
Oscillator Assembly	1	12	3	436B923G01			D
Oscillator Pawl Assembly	1	13	17	794A117G02			D
Oscillator Pawl Spring A	1	13		503B601H11			D
Oscillator Reset Spring	1			@503B601H11			D
Push to Close Button	1	13	8	436B626H01	13	8	436B626H01
Right Hand Spacer A	1	12	14	786A258H02	12	14	786A258H02
Spring Charge Flag	1	13	10	437B396G01	13	10	437B396G01
Spring Charge Indicator Spring	1			@436B621H06	11	9	@436B621H06
Spring Release Latch	1			795A855G01			795A855G01
Spring Release Latch Spring	1			@794A207H01			@794A207H01
Trip Latch	1	11	5	3755A19G01	11	5	3755A19G01
Trip Latch Reset Spring	1	11	7	@795A077H01	11	7	@795A077H01
<b>Following are not included in Mechanism Assembly:</b>							
Emergency Charge Handle A	1	2		349A669G03			D
Manual Charge Assembly (With out handle)	1			D	18		591C385G01
Manual Charge Handle	1			D	18		349A669G01
Opening Spring	1	4		@698B907H01	4		@698B907H01
Trip Shaft Assembly	1	14		349A613G01	14		349A613G01
Trip Shaft Return Spring	1	14	15	@436B621H05	14	15	@436B621H05

- A. Not sold separately
- B. Available only as part of Label Kit on page 5
- C. Included in Main Drive Link Assembly
- D. Not required
- ® Recommended Spare - see page 3

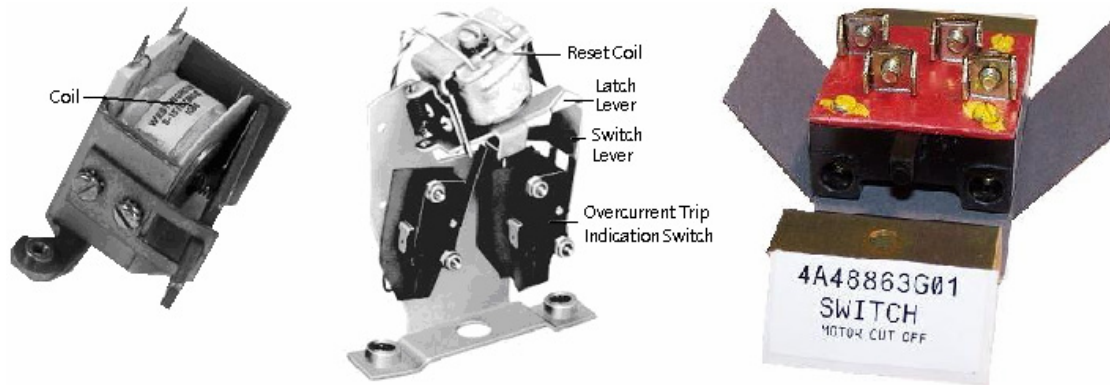

Figure 16 – Left - Shunt trip attachments, Middle – Overcurrent switch, Right – Motor cut off switch

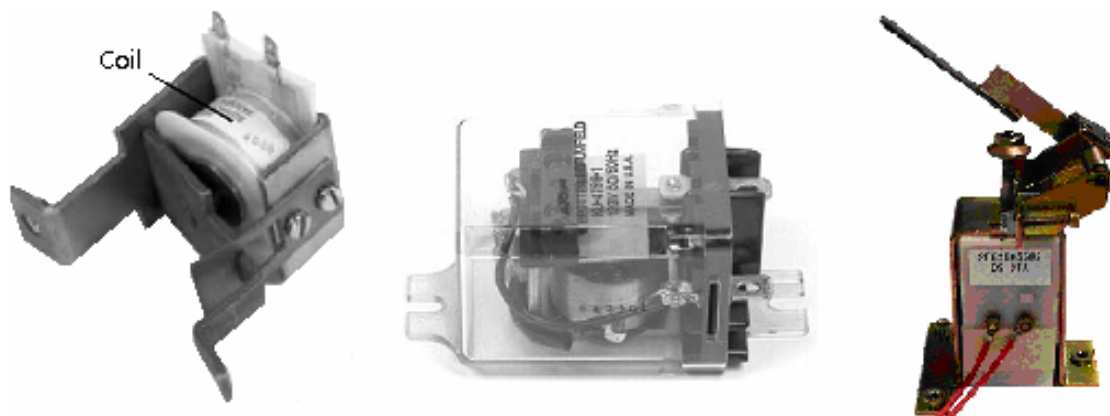

Figure 17 –Left – spring release device, Middle – Anti-pump relay, Right – Typical enhanced direct trip actuator (DTA)



Figure 18 –Left – Charging motor, Right – Manual charging assembly



**Control Components**

Description	Figure Number	Voltage		Part Number
Motor Cut Off Switch includes motor cut off switch, mounting bracket and insulation.	16			4A48863G01
Overcurrent Trip Switch (OTS)	16	125 VDC	2 contact 3 contact	3752A04G06 3752A04G11
		250 VDC	2 contact 3 contact	3752A04G08 3752A04G13
		Manual	2 contact 3 contact 4 contact	3752A04G01 3752A04G02 3752A04G03
Shunt Trip Attachment (STA) A	16	125 VDC 250 VDC 120V 60Hz		5365C59G01 3752A02G05 3752A02G06
® Anti-Pump Relay	17	125 VDC 250 VDC 120V 60Hz		140D930H04 140D930G05 140D930H01
Spring Release Device (SRD) A	17	125 VDC 250 VDC 120V 60Hz		3752A03G02 3752A03G03 3752A03G04
Under voltage Trip Attachment (UVTA) B, C	17	48 VDC 125 VDC		5365C72G01 5365C72G02
®Motor Kit (includes crank and roller and connectors for field replacement)	18	125 VDC 250 VDC 120V 60Hz		449D431G01 449D431G02 449D431G01

- A. Available as a complete assembly only
- B. Include mounting hardware and wire leads for field replacement
- C. Available only as a complete assembly. Coils are not available as a replacement part as they are riveted into the assemblies.
- ® Recommended Spare - see page 3

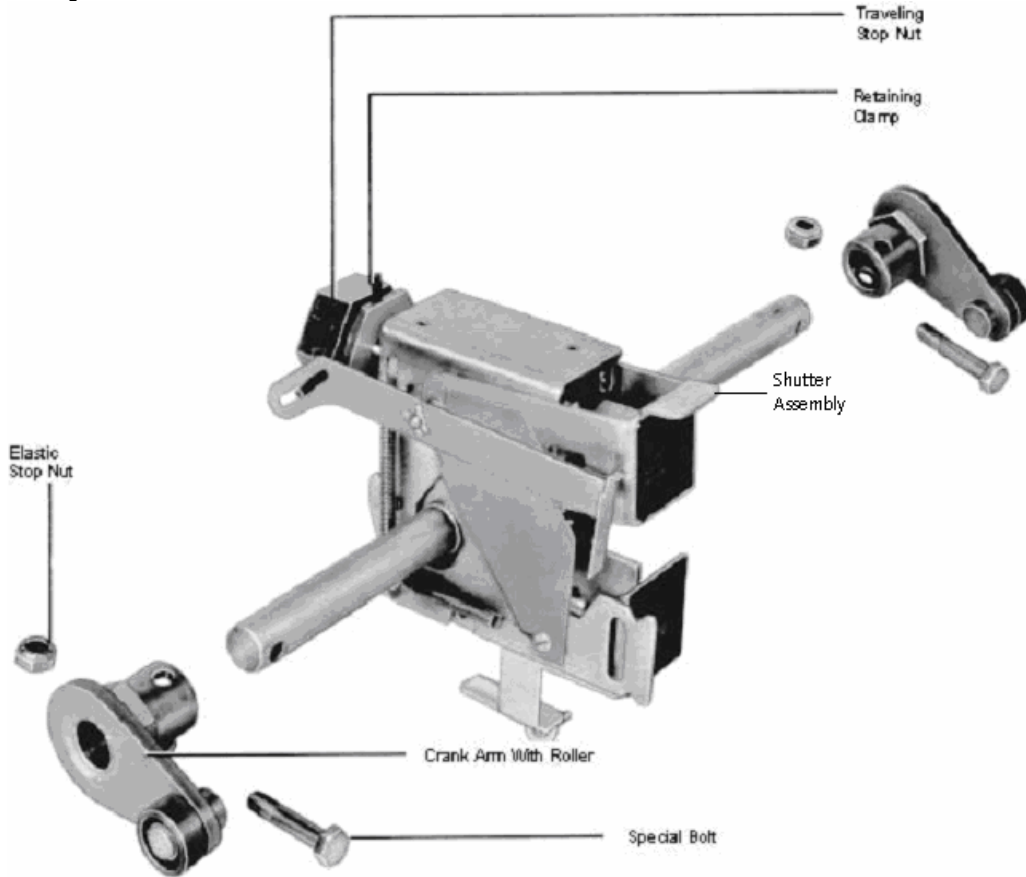

Figure 19 – Levering mechanism assembly

Description	Number Required Per Breaker	Part Number
Levering Mechanism Assembly	1	449D224G04
Following are included in Assembly:		
Traveling Stop Nut	1	791A674H01
Retaining Clamp	1	791A679H01
Nylock Screw (not shown)	2	70001NM28L
Flat Washer	2	70500BD31B
Following are not included in Assembly:		
Crank Arm with Roller	2	786A586G01
Special Bolt	2	792A024H01
Elastic Stop Nut	2	70220ERN18
Lever-in Crank Handle (not shown)	1	436B696G01
Shutter Assembly	1	786A192G01



**Westector Tripping System**



Figure 20 – Westector solid-state trip device

**Westector Solid-State Trip Device**

Westector can be supplied in six combinations of four independent continuously adjustable overcurrent tripping functions:

Long delay (L), Short delay (S), Instantaneous (I), Ground (G)

Model	Part Number
W-LI	2D39995G01
W-LIG	2D39995G02
W-LS	2D39995G03
W-LSG	2D39995G04
W-LSIG	2D39995G05
W-LSI	2D39995G06
Test Procedure	LTR-EMPE-04-9 Rev. 1

**Westector is the only overcurrent trip system currently manufactured and supported by Westinghouse RRAS.**

**Sensors**

See Figure 21 for typical sensors.

Rating Amperes	Part Number
100	151D995G01
150	151D995G15
200	151D995G02
300	151D995G03
400	151D995G04
600	151D995G06
800	151D996G08
1200	151D995G12
1600	151D995G16
2000	151D995G20
2400	151D995G24
3200	151D995G32

Note:  
On type DS-206 / DSL-206 two (2) spacers 794A965H01 are required for each sensor. See Figure 21.

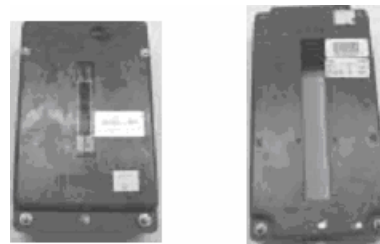

Figure 21 – Left – DS-206 with spacer, Right – DS-632 sensor

Direct Trip Actuator (DTA) A	
Description	Part Number
DTA without Lever	2D82805G01
DTA with Lever	2D82805G02
DTA Frame only B	591C382G01

- A. For compatibility of DTAs with vintage Amptectors, refer to Westinghouse Technical Bulletin NSID-TB-88-05 dated 8-9-88 and LTR-EMPE-04-218.
- B. Use on reactor trip breakers and all non-automatic breakers, those without Westector trip system.
- C. Figure 22 shows Typical Direct Trip Actuator (DTA).



Figure 22 - Typical direct trip actuator (DTA)

- 1. Actuator reset lever
- 2. Plunger
- 3. Actuator reset spring
- 4. Trip shaft adjusting screw
- 5. Magnet Assembly



Auxiliary Switches A	
Contacts	Part Number
a (early), b, a, b	449D622G28
a (early), b, b, b	449D622G29
a, b, a, b	449D622G33
a, a, a, a	449D622G34
b, b, b, b	449D622G35
a, a, a, b	449D622G36
a, b, b, b	449D622G37
a, b, a, b B	449D622G38
a, b, b, b B	449D622G39
a (early), b, b, b, c	449D622G40

a = normally open.  
b = normally closed.

- A. Breaker shop order number is required to properly identify Figure 16-1 - Auxiliary Switches, a 3 high arrangement is shown with one switch.
- B. Reactor trip breaker aux. switches are a three high assembly using G38 at the bottom, G39 at the middle and G40 at the top.
- C. Some reactor trip breaker top aux. switches may use G28 in place of G40.

Auxiliary Switch Accessories	
Description	Part Number
Front Cover With Screw	449D622G09
Rear Cover	13D3172H04

### Auxiliary Switches

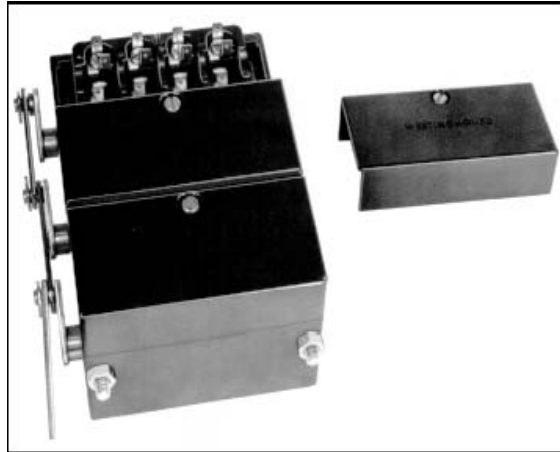

Figure 23 – Auxiliary switches, a 3 high arrangement is shown with one front cover removed.



**DSL-206 and DSL-416 Breakers**

Parts for pole units, arc chutes, mechanism, etc. for DSL breakers are identified on preceding pages of this R.P.D.

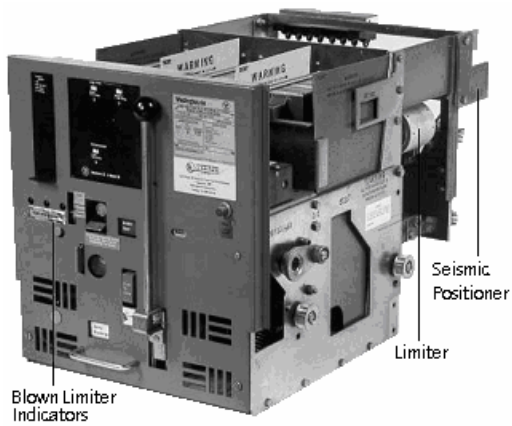

Figure 24 – DSL-206 Breaker – Front View

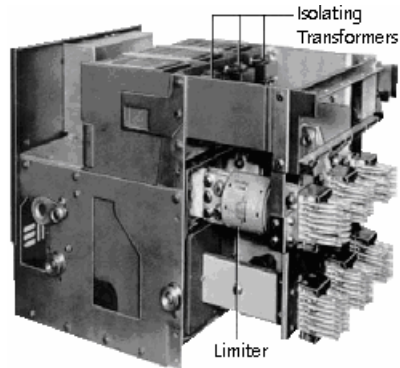

Figure 25 – DSL-416 Breaker – Side View

Description	Figure Number	Number Required per Breaker	DSL-206 and DSL-416 Part Number
Blown Limiter Indicator Assembly	24	1	140D777G01
Isolating Transformer Assembly (includes 3 transformers)	25	1	591C755G01
Transformer only	25	3	795A823H01



© Limiters			
Breaker Type	Number Required per Breaker	Rating Amps	Part Number
DSL-206	3	150	140D316G01
	3	200	140D316G02
	3	250	140D316G03
	3	300	140D316G04
	3	400	140D316G05
	3	600	140D316G06
	3	800	140D316G07
	3	1200	140D316G10
	3	1600	140D316G11
	3	2000	140D316G12
DSL-416	3	800	151D932G01
	3	1000	151D932G02
	3	1200	151D932G03
	3	1600	151D932G04
	3	2000	151D932G05
	3	2500	151D932G09
	3	3000	151D932G10

© Recommend 3 spare limiters of each current rating.

Miscellaneous Switchgear Parts A			
Switchgear Structure Hardware	Figure	Part Number	
<b>Breaker Door Hardware</b>			
Door Handle		436B451H01	
Door Handle Latch		349A364H01	
RTS Rear Door Latch		19B9140G01	
Spacer for Handle Latch		349A366H01	
<b>Bus Work, Contacts and Hardware</b>			
DS-206, DS-416 Cell Interference Bracket	26	436B677H01	
DS-416, DSL-416, DS-420		449D395G01	
DS-632 Insulating Boot with CT B	27	140D768H01	
DS-632 Insulating Boot with out CT B	27	140D769H01	
Insulating Boot with CT B, C		140D294H02	
Insulating Boot with out CT B, C		140D294H01	
Primary Bus Insulator DS-206, DSL-206		449D395G03	
<b>Cell Secondary Contact with hardware D</b>			
6 Long And 2 Short Contacts	26	590C808G02	
8 Long Contacts	26	590C808G01	
Cell Switches E, F			

One Stage	28	590C726G11
Two Stage		590C726G12
<b>Instrument Compartment Door Hardware</b>		
Compartment Latch Assembly		349A904G011
Door Latch Assembly		809A503G01
Cell Switch Lever Assembly		436B954G01
Secondary Contact Mounting Frame		5063640H01
With Cell Switch Operator Bracket		5063640G01
With Mounting Hardware		5063640G02
Spring Retainer Kit		8254C28G03
Lev-in Mounting		
Elastic Stop Nuts - (X2) 10-32		70220ERN18
Nylock Screws - (X2) 10-32 x 0.5"		70001NM28L
Push To Trip Linkage	26	588C777G02

- A. See page 3 for service limits on certain cell parts
- B. 6 required per compartment
- C. For use in all DS/DSL cells except for DS-532/632
- D. Includes 591C497G01 or 591C497G02 and Mounting Hardware.
- E. Switchgear shop order number is required to properly identify switch type.
- F. Some foreign plant reactor trip switchgear assemblies have cell switches with special mounting brackets.

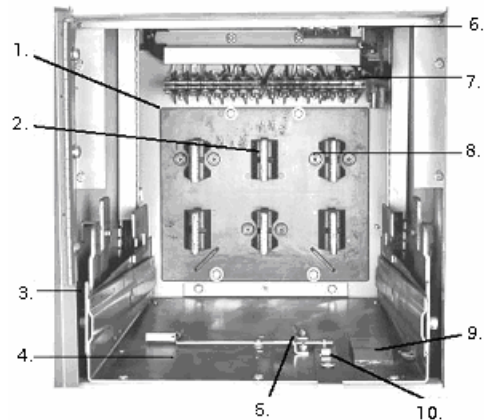

Figure 26 – Typical DS-416 Breaker Compartment

- 1. Contact Mounting Plate
- 2. Stationary Main Contact
- 3. Captive Draw out Extension Rail
- 4. Breaker Mounting Pan
- 5. Interference Bracket DS-206, DS-416
- 6. Cell Switch
- 7. Secondary Contact Blocks
- 8. Current Transformer Mounting Holes
- 9. Ground Contact
- 10. Push To Trip Mechanism

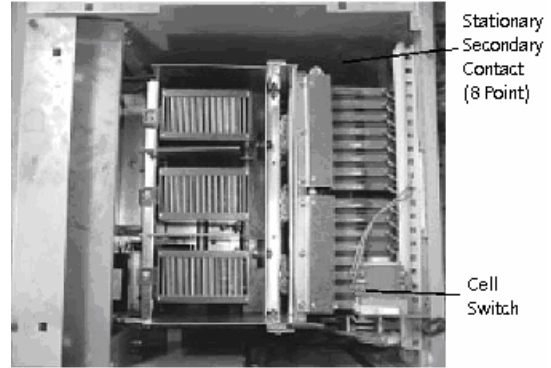

Figure 28 – Top view of DS breaker in cell

Miscellaneous Switchgear Parts (continued)

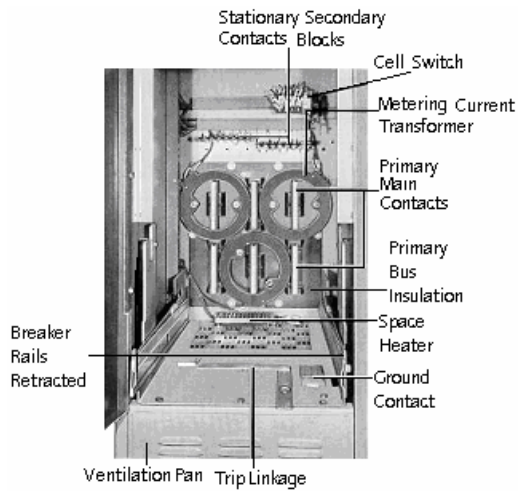

Figure 27 - Typical DS-632 breaker compartment

Current Transformer Kits A				
Type	Circuit Breaker Type	Ratio	Figure Number	Part Number
DSM-16	DS-206	100:5		3A73103G01
	DSL-206	150:5		3A73103G02
	DS-416	200:5		3A73103G03
	DSL-416	250:5		3A73103G04
	DS-420	300:5		3A73103G05
		400:5		3A73103G06
		500:5		3A73103G07
		600:5		3A73103G08
		800:5		3A73103G09
		1000:5		3A73103G10
		1200:5		3A73103G11
		1500:5		3A73103G12
		1600:5		3A73103G13
	2000:5		3A73103G14	
	2500:5		3A73103G15	
	3000:5		3A73103G16	
DSM-32	DS-532	2400:5	28	3A73103G17
	DS-632	2500:5	28	3A73103G18
		3000:5	28	3A73103G19
		3200:5	28	3A73103G20
		4000:5	28	3A73103G21

A. To be used for metering and instrumentation only, not for relaying



#### PROCEDURE FOR IDENTIFYING BREAKER TYPE

A breaker is identified by the data found on the nameplate. Shop Order or S.O. numbers are used to identify breakers. Examples are:

24Y7859  
27Y3838  
48Y2912  
49Y7666  
02YN085  
860.507

#### For Pricing Information

All of the part numbers in this Renewal Parts Data Book are listed on Rapid EIDMS. Rapid EIDMS can be found at:

[http://www.westinghousenuclear.com/Businesses/Nuclear\\_Services/rras\\_rapid\\_eidms.shtm](http://www.westinghousenuclear.com/Businesses/Nuclear_Services/rras_rapid_eidms.shtm)

For information on products and Services:

[http://www.westinghousenuclear.com/Products\\_&\\_Services/nuclear\\_services/rras\\_services.shtm](http://www.westinghousenuclear.com/Products_&_Services/nuclear_services/rras_services.shtm)

Contact your Nuclear Parts Specialist. Find their information at:

[http://www.westinghousenuclear.com/Businesses/Nuclear\\_Services/rras\\_customer\\_service.shtm](http://www.westinghousenuclear.com/Businesses/Nuclear_Services/rras_customer_service.shtm)

If you do not have access to Rapid EIDMS, visit [www.westinghousenuclear.com](http://www.westinghousenuclear.com) and follow the path:

[Westinghouse](#) : [Businesses](#) : [Nuclear Services](#) : RRAS Marketing Contacts: RRAS Contact Us

#### Ordering Instructions

1. Check the nameplate to identify the type of breaker you have. (If adding accessories or options to existing breakers, please also provide the shop order information.)
2. Identify the part(s) from the photos and tables from the preceding pages.
3. Determine the part number for the required parts.
4. Specify the quantity required.
5. Specify whether it is a Safety or Non-Safety application.
6. Contact Westinghouse Repair, Replacement & Automation Services at 1-800-458-2206, or fax to 724-722-5462.
7. State the method of shipment.